

PMA - DFP
interamente intubato

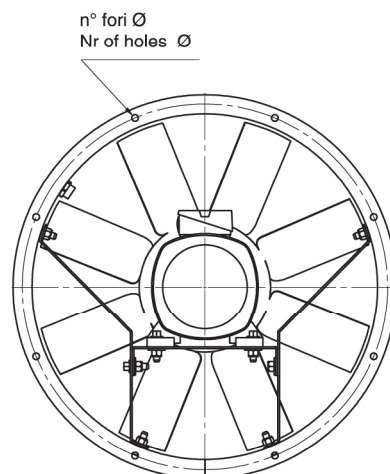

Modello Type	Motore Motor	Dimensioni Dimensions						Fori Holes		Peso Weight
		C	D	E	F	G	T	n°	Ø	kg
310	63	315	305	300	348	378	1,5	6	11	9
	71	315	305	300	348	378	1,5	6	11	13
350	63	360	350	300	400	423	1,5	6	11	11
	80	360	350	300	400	423	1,5	6	11	15
400	63	410	400	300	448	473	1,5	6	11	15
	71	410	400	300	448	473	1,5	6	11	18
	80	410	400	300	448	473	1,5	6	11	21
450	100	410	400	300	448	473	1,5	6	11	32
	71	460	450	400	495	523	1,5	6	11	20
	80	460	450	400	495	523	1,5	6	11	25
500	100	460	450	400	495	523	1,5	6	11	36
	71	510	500	450	545	573	1,5	8	11	28
	80	510	500	450	545	573	1,5	8	11	34
560	132	510	500	450	545	573	1,5	8	11	70
	71	570	560	500	605	633	1,5	8	11	33
	80	570	560	500	605	633	1,5	8	11	35
	90	570	560	500	605	633	1,5	8	11	35
630	132	570	560	500	605	633	1,5	8	11	70
	80	640	630	500	675	704	2	8	11	40
	90	640	630	500	675	704	2	8	11	50
	100	640	630	500	675	704	2	8	11	58
710	132	640	630	500	675	704	2	8	11	90
	90	710	700	500	745	774	2	12	14	65
	100	710	700	500	745	774	2	12	14	71
	112	710	700	500	745	774	2	12	14	75
800	132	710	700	500	745	774	2	12	14	103
	90	810	800	560	855	884	2	12	14	75
	100	810	800	560	855	884	2	12	14	90
	112	810	800	560	855	884	2	12	14	55
900	132	810	800	560	855	884	2	12	14	106
	100	910	900	650	955	1004	3	16	14	110
	112	910	900	650	955	1004	3	16	14	130
	132	910	900	650	955	1004	3	16	14	180
1000	100	1010	1000	650	1070	1104	3	16	14	130
	112	1010	1000	650	1070	1104	3	16	14	140
	132	1010	1000	650	1070	1104	3	16	14	180
	160	1010	1000	650	1070	1104	3	16	14	210
1120	132	1130	1110	900	1185	1240	3	20	16	185
	160	1130	1110	900	1185	1240	3	20	16	245
	180	1130	1110	900	1185	1240	3	20	16	310
1250	160	1260	1238	1000	1320	1370	3	20	16	210
	180	1260	1238	1000	1320	1370	3	20	16	280
1400	180	1410	1380	1120	1465	1520	3	20	16	425
	200	1410	1380	1120	1465	1520	3	20	16	485
	250	1410	1380	1120	1465	1520	3	20	16	500

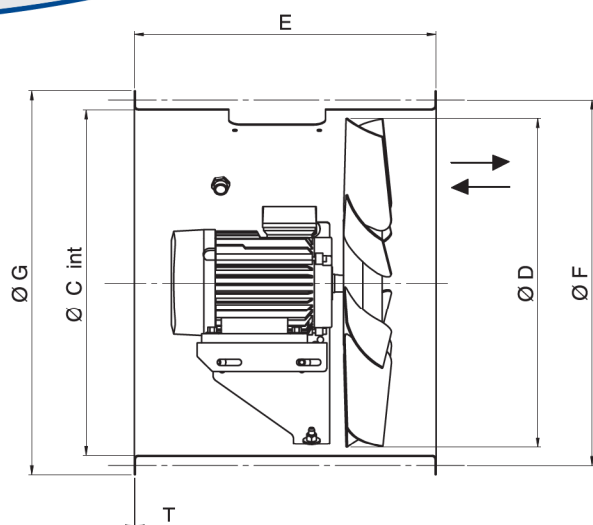
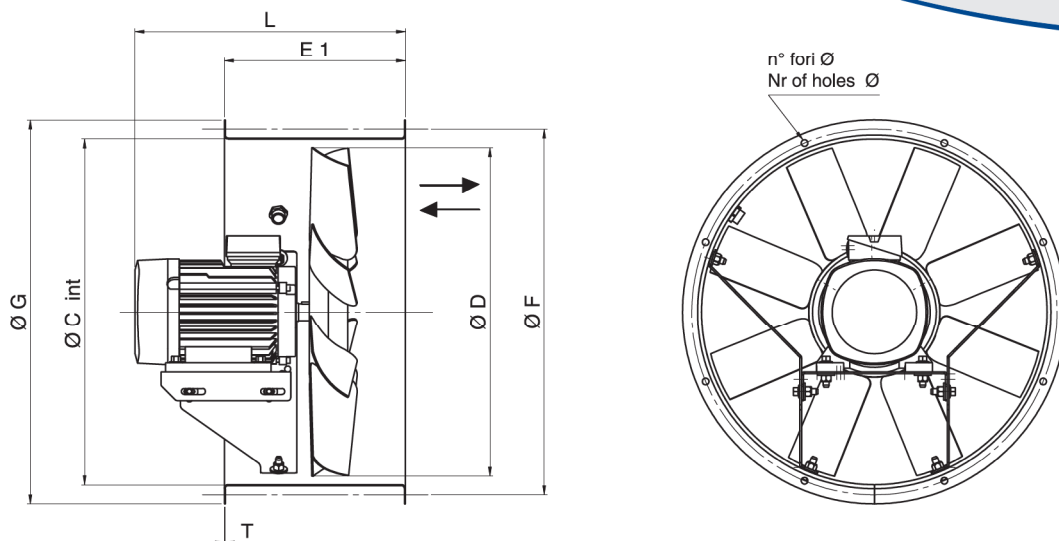

Modello Type	Motore Motor	Dimensioni Dimensions							Fori Holes		Peso Weight kg
		C	D	E1	F	G	L	T	n°	Ø	
310	63	315	305	200	348	378	295	1,5	6	11	7
	71	315	305	200	348	378	330	1,5	6	11	11
350	63	360	350	215	400	423	295	1,5	6	11	7,5
	80	360	350	215	400	423	400	1,5	6	11	11,5
400	63	410	400	215	448	473	315	1,5	6	11	11
	71	410	400	215	448	473	330	1,5	6	11	13
	80	410	400	215	448	473	410	1,5	6	11	17,5
450	100	410	400	215	448	473	465	1,5	6	11	28
	71	460	450	230	495	523	330	1,5	6	11	14
	80	460	450	230	495	523	410	1,5	6	11	19
500	100	460	450	230	495	523	470	1,5	6	11	30
	71	510	500	270	545	573	350	1,5	8	11	22
	80	510	500	270	545	573	410	1,5	8	11	24
560	132	510	500	270	545	573	590	1,5	8	11	60
	71	570	560	300	605	633	360	1,5	8	11	23
	80	570	560	300	605	633	420	1,5	8	11	25
	90	570	560	300	605	633	450	1,5	8	11	25
630	132	570	560	300	605	633	610	1,5	8	11	65
	80	640	630	300	675	704	420	2	8	11	26
	90	640	630	300	675	704	450	2	8	11	39
	100	640	630	300	675	704	510	2	8	11	44
710	132	640	630	300	675	704	640	2	8	11	80
	90	710	700	300	745	774	450	2	12	14	48
	100	710	700	300	745	774	510	2	12	14	55
	112	710	700	300	745	774	530	2	12	14	60
800	132	710	700	300	745	774	630	2	12	14	83
	90	810	800	350	855	884	470	2	12	14	55
	100	810	800	350	855	884	510	2	12	14	60
	112	810	800	350	855	884	540	2	12	14	70
900	132	810	800	350	855	884	640	2	12	14	84
	100	910	900	500	955	1004	530	3	16	14	80
	112	910	900	500	955	1004	560	3	16	14	100
	132	910	900	500	955	1004	680	3	16	14	150
1000	100	1010	1000	500	1070	1104	530	3	16	14	100
	112	1010	1000	500	1070	1104	560	3	16	14	135
	132	1010	1000	500	1070	1104	680	3	16	14	165
	160	1010	1000	500	1070	1104	780	3	16	14	180
1120	132	1130	1110	550	1185	1240	680	3	20	16	135
	160	1130	1110	550	1185	1240	830	3	20	16	185
	180	1130	1110	550	1185	1240	880	3	20	16	270
1250	160	1260	1238	550	1320	1370	830	3	20	16	130
	180	1260	1238	550	1320	1370	880	3	20	16	220
1400	180	1410	1380	550	1465	1520	880	3	20	16	345
	200	1410	1380	550	1465	1520	980	3	20	16	395
	250	1410	1380	550	1465	1520	1130	3	20	16	450